

JEWELLED
BEARING

INSPECTION
CERTIFICATE

LARGE RANGE DIAL TEST INDICATOR

- Dial reading: 0-40-0
- Jeweled bearing
- Carbide contact point
- Two measuring directions
- Anti magnetic body
- Supplied with two clamps:
diameter $\text{\O}4\text{mm}$ and $\text{\O}8\text{mm}$
- Optional accessory: styli



2386-16A

clamp (included)

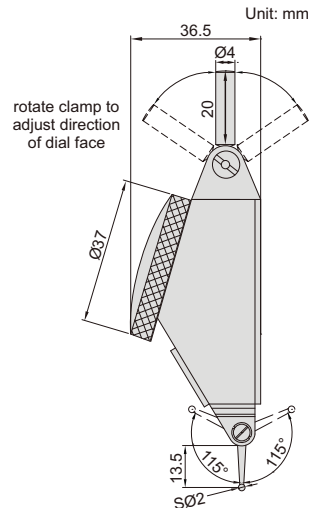
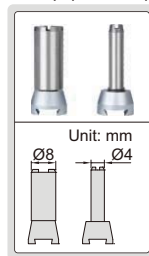

Code	Range	Graduation	Accuracy	Hysteresis
2386-16A*	1.6mm	0.01mm	25 μm	8 μm

*Supplied with manufacturer inspection certificate